

# Technical Data Sheet

## Shower Systems

# TAVISTOCK

No.	Description	Code	Fixings Included
1	Lansdown 2F Exposed Shower System	SLD1701, SLD1702	YES



FLOW RATE DATA IS TESTED UNDER LABORATORY CONDITIONS: ACTUAL FLOW RATE MAY VARY DEPENDING ON DOMESTIC SUPPLY AND ACCESSORIES

Minimum Pressure:	1 BAR
Inlet Pressure	Flow Rate (l/min)
0.5 bar	9.6
1 bar	14.7
2 bar	21.9
3 bar	26.1

## Dimensions - Overview

Diagrams not to scale. All dimensions in mm (tolerance of +/-5mm)

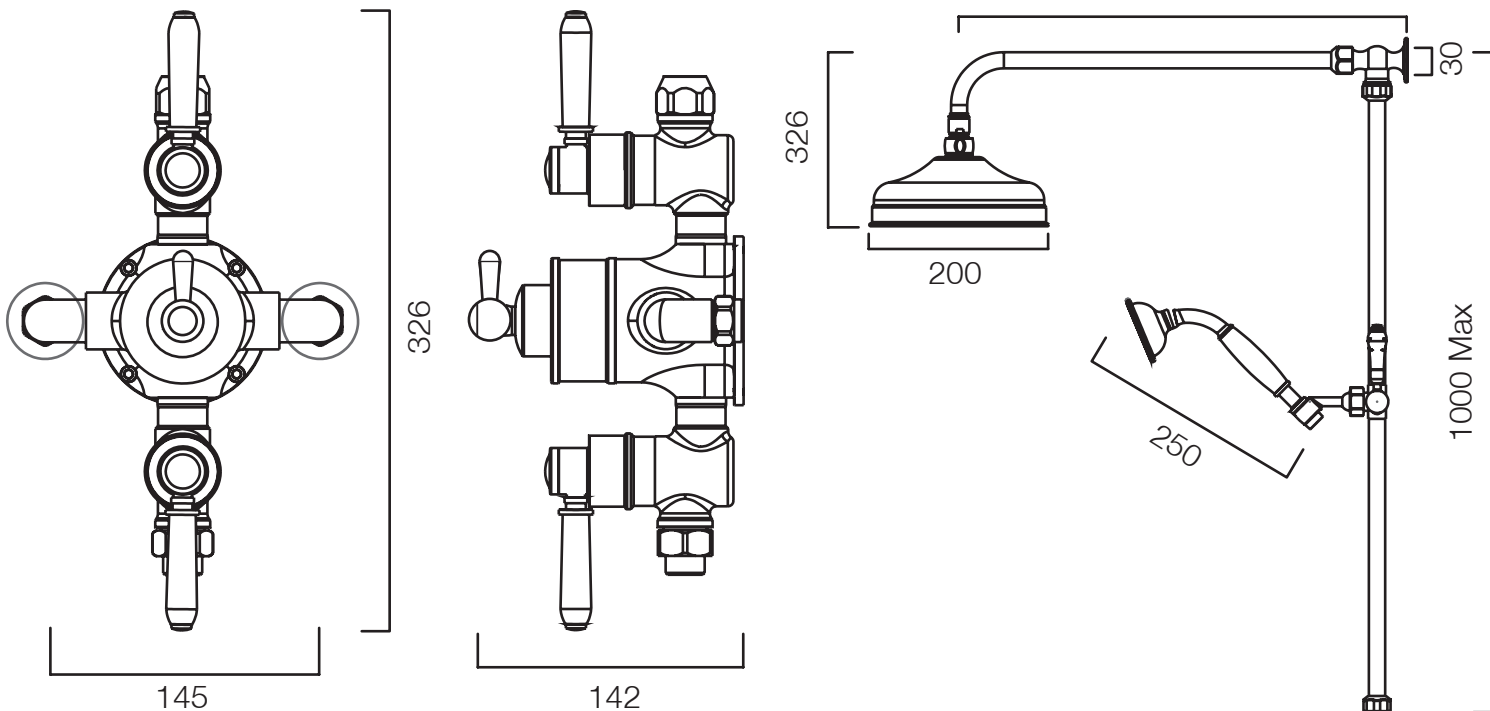

## FAQs

**How tall is the riser rail?** 1000mm - this can be cut down if necessary

**How long is the shower hose?** 1.5m

**What is the minimum pressure for the valve?** 1.0bar

**What is the valve connection size?** 1/2" suitable for 15mm pipework