

### **Cosmetic repairs to your bath**

Should you be unfortunate enough to suffer cosmetic damage to your bath during installation or accidentally at any time, these can usually be rectified quite easily by using a fine grade abrasive waterproof paper. Lightly rub the affected area by keeping the area treated to a minimum until the mark is removed, then polish a neutral car colour restorer or a household metal polish to restore the luster.

Other marks on your bath both internally or externally can generally be removed with a non abrasive bathroom cleaner or mild detergent. Should this not be the case then please revert to colour restorer or household metal polish.

### **Ongoing care of your bath**

Use only non abrasive cleaners as abrasives over a period of time will remove the luster from your bath.

### **Warning**

Never use cleaners / bleach products specifically manufactured for WC bowl cleaning as they may damage your bath. Bath mat or suction pad might cause damage to the surface over time and must be avoided.

- THIS IS A SUGGESTED TAP HOLE DRILLING GUIDE ONLY. THE DECK MOUNTING UNIONS ENABLE THE TAP CENTRES TO BE DRILLED BETWEEN 60MM AND 300MM. THE FINAL DECISION MUST BE MADE ONSITE DEPENDING ON THE DESIRED LOCATION OF THE PRODUCT.

- IN THE EVENT THAT YOU ARE USING DECK MOUNTED TAPS THEN YOU SHOULD DRILL THE TAP HOLES IN THE POSITIONS MARKED BELOW.

FIT TO MATCH TOP EDGE OF TUB

180

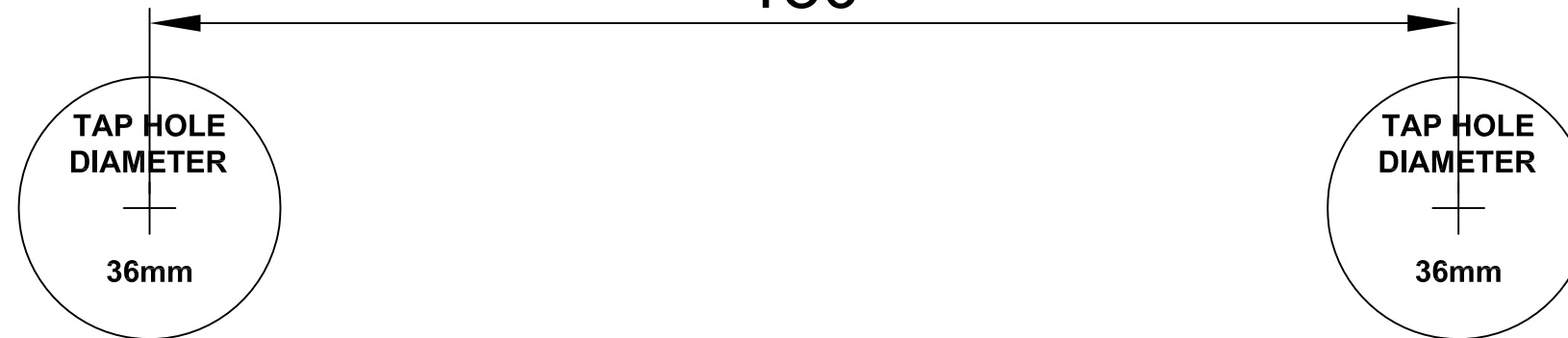

FIT TO MATCH TOP EDGE OF TUB

- **EVERY BATH REQUIRES AN OVERFLOW.**  
IN THE EVENT THAT YOU ARE NOT USING THE INVISIBLE OVERFLOW OR EXTERNAL OVERFLOW THEN YOU SHOULD DRILL IN THE POSITION MARKED BELOW.

NOTE: BEFORE DRILLING  
ENSURE HOLE IS CENTRED TO WASTE HOLE  
AFTER DRILLING  
APPLY 100% SILICON SEALANT AT THE CUTTING EDGE OF THE OVERFLOW HOLE.

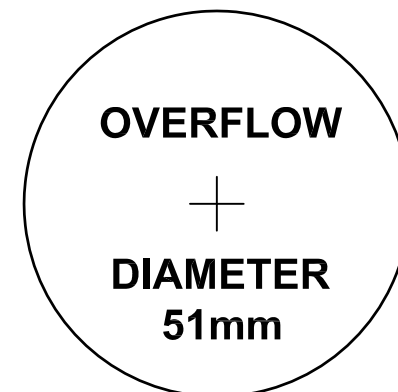

**Windsor Double Ended 1700 – E3**  
**Windsor Double Ended 1500 – E4**